

KH-1500 正反双头锁边机

FRONT AND BACK DOUBLE-HEAD MATTRESS SEWING MACHINE



噪音小



耐磨损



速度快



精度高



高效



稳定



自动收送料装置
Automatic cloth feeding
and collecting device



两个独立锁边机头同步工作
Two separate side-lock
heads to work together



TECHNICAL PARAMETERS 技术参数

锁边宽度范围 Border Flanging Width	50~450mm
锁边速度 Side-lock Speed	15~30m/min
缝纫厚度 Sewing Thickness	≤35mm
针步 Stitch Length	2~6mm
总功率 Total Power	1.5KW
重量 Total Weight	220V 50HZ

INSTALLATION DIMENSION 安装尺寸

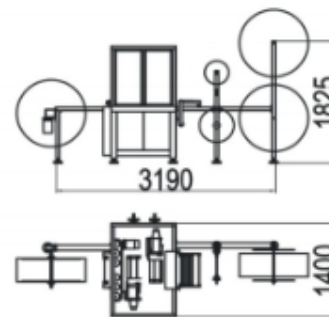

PRODUCT INFORMATION 产品信息

- 直驱伺服电机控制机头的同步驱动；
Equipped with direct-driven servo motor to control heads with synchronous drive;
- 可调式面料涨紧装置及收卷机构，自动剪去锁边的多余面料；
Adjustable fabric expanding device and rolling mechanism can automatically cut the cloth unnecessary for side-lock;
- 可与围条花样机配套使用。
It can be combined with double heads border quilting machine.

evotec.com.br